

M-TDV

- Up to 18 ports
- Inflatable seals
- All product contact surfaces FDA approved
- Converging and diverging applications
- Pressures up 1 bar g, optional up to 3 bar g
- Temperature range -15 °C to +80 °C
- Compact design
- Versions conforming to ATEX 94/9/EC available

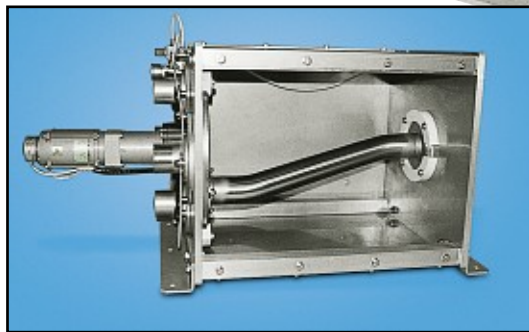
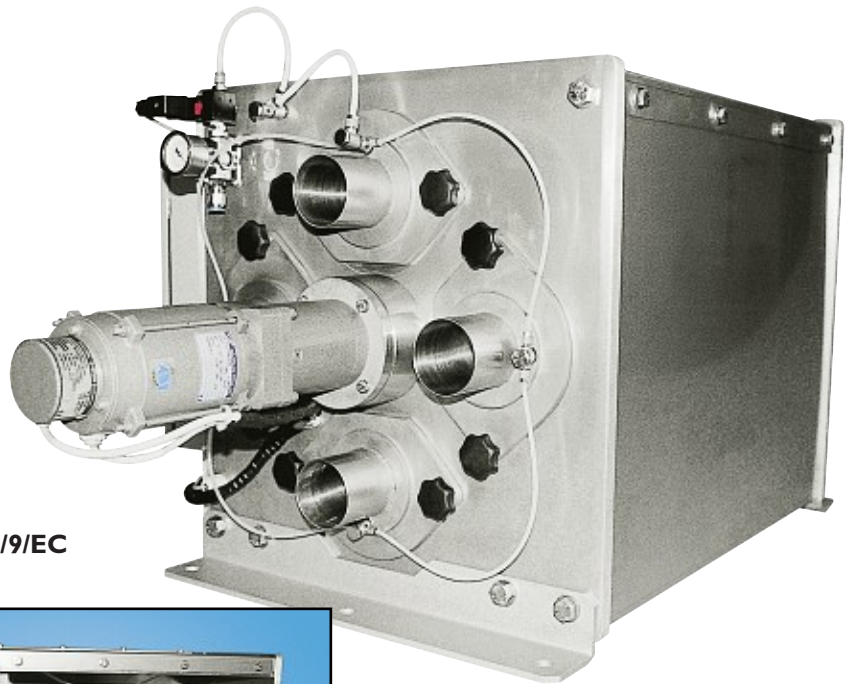

M-TDV Multi-port diverter valve

The DMN-WESTINGHOUSE M-TDV diverts pneumatically conveying products in powder or pellet form to multiple destinations (diverging). Or from multiple sources to one destination (converging).

The M-TDV design is simplicity itself, and guarantees a high positional accuracy with a minimum of component parts. Available in sizes from 40 to 150 mm (1,5" to 6"), with up to 18 ports on the smaller models.

The normal supply would consist of the diverter unit, a pre-programmed compact frequency inverter and a ladder diagram to suit a PLC. A PLC is available as an optional extra, but is not generally supplied by DMN-WESTINGHOUSE.

Product information

All product contact surfaces are manufactured in AISI 316 stainless steel and FDA approved materials. The inflatable seals are in FDA approved polyurethane. The standard aluminium cover is suitable for most applications. An alternative AISI 316 stainless steel cover is available.

The unit can be mounted either horizontally or vertically and is driven by means of a backlash free geared motor, combined with an encoder which together with the frequency inverter and a PLC guarantees a very accurate alignment of the conveying lines. A uniform smooth bore pipe between the inlet and outlet allows a constant velocity, minimises pressure loss, reduces product degradation and ensures clean purging. Seals are located outside the product flow, inflate on position confirmation and deflate during switching automatically. The indexing tube plate seals off unused ports.

The standard version can be used in systems with pressures up to 1 bar g. An optional version for the use up to 3 bar g is also available.

M-TDV

Technical modifications are possible, dimensions in mm M-TDV.M.01.00.1

X outlets $\varnothing A$
equally spaced on B inch PCD

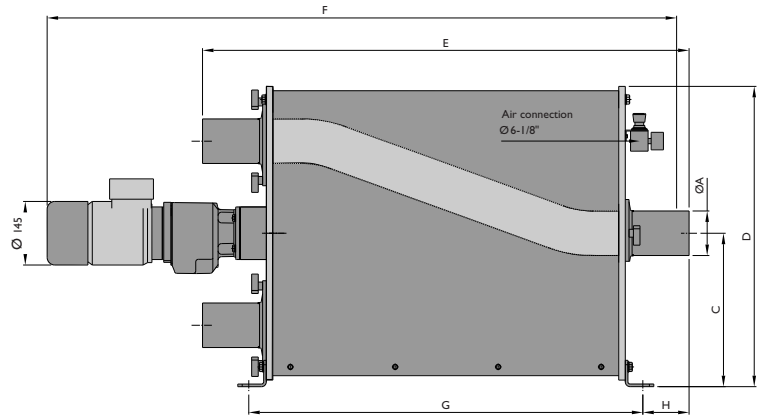
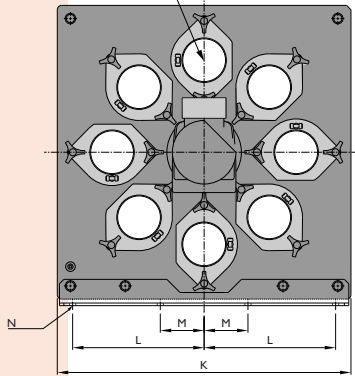

DMN-WESTINGHOUSE have been designing and manufacturing rotary valves, diverter valves and other related components for the bulk solids handling industry for more than 30 years. Offering tailor made solutions for chemical, food, plastics and pharmaceutical industries, DMN-WESTINGHOUSE products are distributed worldwide. Besides an extensive range of standard components, we supply USDA accredited sanitary versions and ATEX approved explosion-proof models. An extensive network of subsidiaries, distributors and representatives ensures a high level of service and support all over the world.

	Size	$\varnothing A$	X	B	C	D	E	F	G	H	K	L	M	N
Module I	40	38,1x1,5	3 4 5 6	370	310	605	1049	1402	833	108	590	265	-	3 HOLES $\varnothing 14$
	50	50,8x1,5												
	65	63,5x1,5	3											
	80	76,1x1,5	4											
	100	101,6x2												
Module II	40	38,1x1,5	7 8 9 10 11 12	420	350	685	1115	1334	899	108	670	300	100	4 HOLES $\varnothing 14$
	50	50,8x1,5												
	65	63,5x1,5	5											
	80	76,1x1,5	6											
	100	101,6x2	7 8											
Module III	65	63,5x1,5	9 10 11 12	600	475	935	1385	1604	1169	108	920	400	150	4 HOLES $\varnothing 14$
	80	76,1x1,5												
	100	101,6x2												
	125	129x2	3 4											
	150	154x2	5 6											

Head Office:
DMN Machinefabriek Noordwykerhout BV
PO Box 6, NL - 2210 AA Noordwykerhout, Holland
Tel. +31 252 361 800
Fax +31 252 375 972/934
dmn@dmn-nwh.nl

DMN Incorporated
3895 South Perkins Road, Suite 8
Memphis, TN 38118, USA
Tel. +1 901 360 1537
Fax +1 901 360 0348
dmnfo@dmn-inc.com

DMN Schüttguttechnik GmbH
Rütgersstrasse 8
D-21244 Buchholz i.d. Ndh, Germany
Tel. +49 4181 931 40
Fax +49 4181 931 490
dmn@dmn-schuettguttechnik.de

DMN UK Ltd
Unit 1&2, Harris Road,
Porte Marsh Industrial Estate
Calne, Wiltshire, SN 11 9PT, UK
Tel. +44 1249 818 400
Fax +44 1249 818 410
dmn@dmnuk.com

DMN France SAS
65, rue Charles de Gaulle
91330 Yerres, France
Tel: +33 1 69 49 85 70
Fax: +33 1 69 49 85 79
dmnfrance@wanadoo.fr

© DMN - HOLLAND - 04/05



www.dmn.info

DMN
WESTINGHOUSE