

- Saving system costs
- Compact design
- Easy maintenance
- Optimal sealing
- Flange or pipe fittings
- Flanges drilled in accordance with PN 10 and ANSI 150 lbs
- Cast iron, aluminium or stainless steel
- Versions conforming to ATEX 94/9/EC available

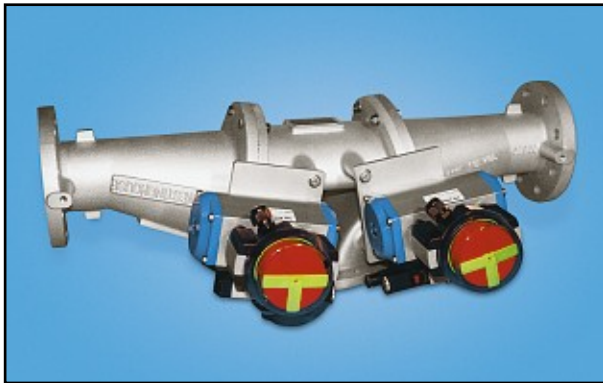

## FVV Fill Vent Valves

The DMN-WESTINGHOUSE FVV fill vent valves or weigh valves can be used in bulk handling systems where product is pneumatically conveyed to a silo or hopper that is process weighed. The FVV is ideally suitable for food and chemical industries.

The valve can be used to discharge the product into a silo, while the air is exhausted. When the required weight in a silo has been reached, the valve changes position by means of two actuators. The product is then sent to alternative weigh stations or conveyed back to the main storage silo. Only one filter unit is required for the complete system, thus saving considerable system costs.

The FVV is available in two versions: the FVV-F type with flange fittings and the FVV-P type with pipe fittings. Both versions are available in aluminium, cast iron and stainless steel, in the ranges 50 - 150. Larger versions are available on request.

The two internal parabolic flaps are operated by pneumatic actuators.

## Product information

The robust body is manufactured in three sections split at the flanges, giving direct access to the internal sealing flap. The parabolic style stainless steel flap assembly is fitted with a wear resistant polyurethane seal, providing a virtually leak proof non-contaminating unit. A food quality polyurethane seal is optionally available.

The FVV valve can be used in systems with positive pressures up to 1 bar g and negative pressures up to 300 mbar g. The standard polyurethane flap can be used for temperatures up to 80 °C. Options for higher temperatures are available on request.

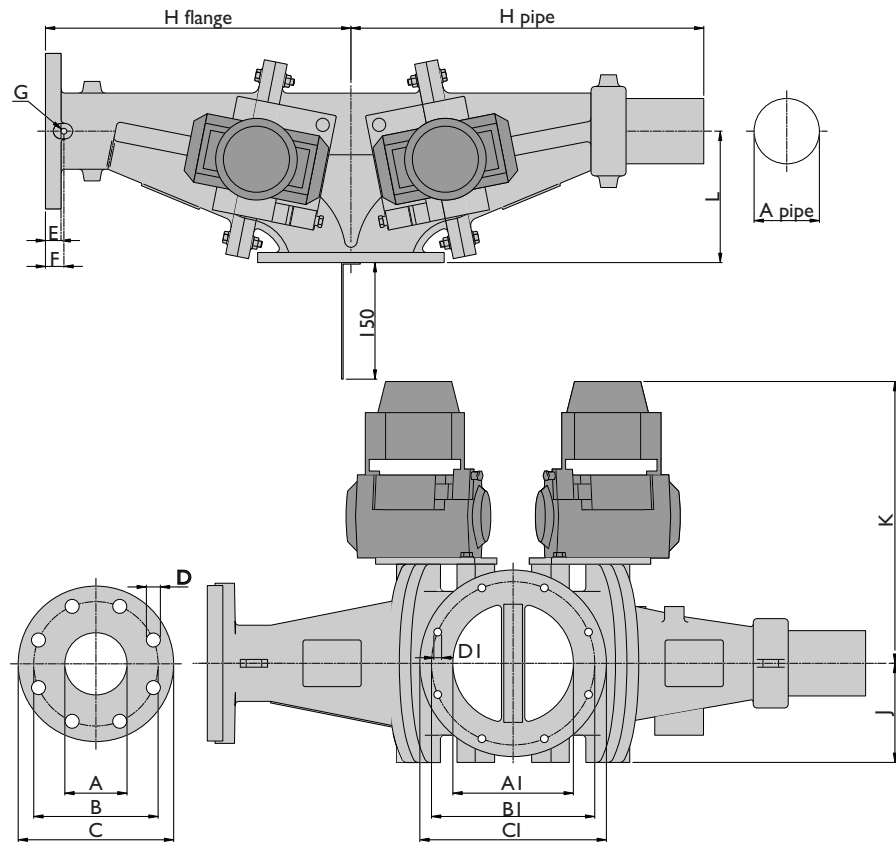

DMN-WESTINGHOUSE have been designing and manufacturing rotary valves, diverter valves and other related components for the bulk solids handling industry for more than 30 years. Offering tailor made solutions for chemical, food, plastics and pharmaceutical industries, DMN-WESTINGHOUSE products are distributed worldwide. Besides an extensive range of standard components, we supply USDA approved sanitary versions and explosion-proof models. An extensive network of subsidiaries, distributors and representatives ensures a high level of service and support all over the world.

Type FVW	FVW P*			DIN		ANSI					
	ØA	ØA(AISI)	ØA(St.37)	ØB	D	ØC	ØB	D	ØAI	ØBI	ØCI
50	50	Ø54x2	Ø54x2,6	125	4xØ18	165	120,6	4xØ19	105	160	190
65	65	Ø70x2	Ø70x2,9	145	4xØ18	185	139,7	4xØ19	120	180	200
80	80	Ø84x2	Ø88,9x4	160	8xØ18	200	152,4	4xØ19	155	210	240
100	100	Ø104x2	Ø108x3,6	180	8xØ18	220	190,5	8xØ19	185	240	260
125	125	Ø129x2	Ø133x4	210	8xØ18	250	215,9	8xØ22,2	215	270	290
150	150	Ø154x2	Ø159x4,5	240	8xØ22	285	241,3	8xØ22,2	245	325	355

Type FVW	DI	E	F	G	H flange	H pipe	J	K	L
50	8xØ10	18	19	M8x12	315	375	103	321	157
65	8xØ10	18	19	M8x12	341	401	110	328	165
80	8xØ10	20	24	M8x12	393	454	128	363	169
100	8xØ10	20	24	M8x12	432	488	143	376	216
125	8xØ10	22	24	M8x12	486	544	165	410	284
150	8xØ12	22	24	M8x12	528	586	185	430	285

\* Other pipe diameters on request

**Head Office:**  
**DMN Machinefabriek Noordwykerhout BV**  
 PO Box 6, NL - 2210 AA Noordwykerhout, Holland  
 Tel. +31 252 361 800  
 Fax +31 252 375 972/934  
 dmn@dmn-nwh.nl

**DMN Incorporated**  
 3895 South Perkins Road, Suite 8  
 Memphis, TN 38118, USA  
 Tel. +1 901 360 1537  
 Fax +1 901 360 0348  
 dmnfo@dmn-inc.com

**DMN Schüttguttechnik GmbH**  
 Rütgersstrasse 8  
 D-21244 Buchholz i.d. Ndh, Germany  
 Tel. +49 4181 931 40  
 Fax +49 4181 931 490  
 dmn@dmn-schuettingtechnik.de

**DMN UK Ltd**  
 Unit 1&2, Harris Road,  
 Porte Marsh Industrial Estate  
 Calne, Wiltshire, SN 11 9PT, UK  
 Tel. +44 1249 818 400  
 Fax +44 1249 818 410  
 dmn@dmnuk.com

**DMN France SAS**  
 65, rue Charles de Gaulle  
 91330 Yerres, France  
 Tel: +33 1 69 49 85 70  
 Fax: +33 1 69 49 85 79  
 dmnfrance@wanadoo.fr