

AL-BL DAIRY

- USDA* approved
- Easy removal of rotor for fast and efficient cleaning
- Smooth product contact surfaces in food grade material
- Rotor pockets radiused and polished to $R_a = 0.8 \mu\text{m}$ (150 grit)
- Rotor vanes chamfered on all edges
- Flame proof and explosion shock resistant versions available
- Flameproof versions available suitable for St2 products
- Versions conforming to ATEX 94/9/EC available

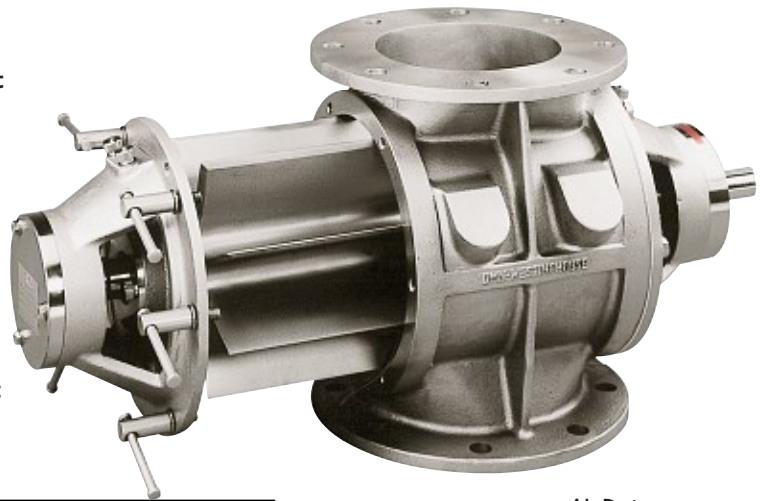

AL-Dairy



BL-Dairy



AL-BL Dairy valves

The DMN-WESTINGHOUSE AL air lock and BL blow through Dairy valves have been designed for use in the food, chemical and pharmaceutical industries where very high standards apply.

The construction of the valve is designed to avoid bacteriological contamination. All product contact surfaces are in food grade material and smoothly polished.

The Dairy valves are available in 6 sizes covering a capacity range from approximately 2.5 to 58 litre per revolution at 100 % filling.

The valves have a USDA certificate of approval for use in dairy plants.

Product information

The body and end covers are made from AISI 316 stainless steel (DIN 1.4408). The rotor is made from AISI 316L (DIN 1.4404).

Shaft sealing can be glands or air purge.

The standard models are suitable for temperatures up to 80 °C and a pressure up to 2 bar g.

Flame proof and explosion shock resistant versions up to 10 bar g are also available.

*United States Department of Agriculture

The AL and BL Dairy valves are also available in MZC version with centrally placed supporting bars for easy removal of end cover and rotor. (see also photograph on last page)

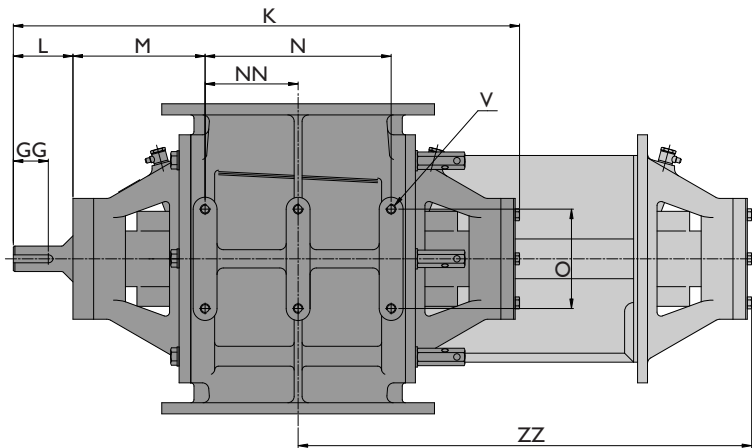
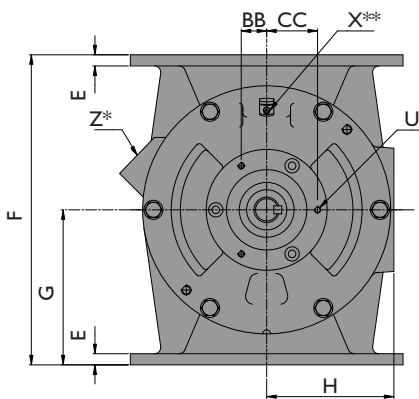
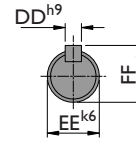
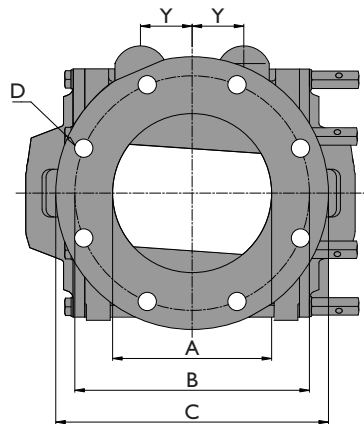

* Standard not pre-drilled
 Standaard niet voorgeboord
 Standard nicht gebohrt
 Standard pas percé
 Standard no taladrado
 Standard non preforato

** Air purge connection
 Aansluiting luchtafdichting
 Luftspülanschluss
 Connexion insufflation d'air
 Entrada aire fluidificación
 Ingresso aria di flussaggio

<--DISASSEMBLY DIMENSION-->
 <--DEMONTAGEMAAT-->
 <--DEMONTIERMASSE-->
 <--DIMENSION DE DÉMONTAGE-->
 <--DIMENSIONES DE DESMONTAJE-->
 <--DIMENSIONI INGOMBRO SMONTAGGIO-->

Type AL	Ltr/rev	DIN				ANSI		E	F	G	H	K	L	M	N	NN
		ØA	ØB	D	ØC	ØB	D									
150	2,5	150	240	8xØ23	285	241,3	8xØ22,2	12	280	140	110	521	72	151	146	—
175	5,5	175	270	8xØ23	315	—	—	14	330	165	130	561	72	149	190	—
200	10,5	200	295	8xØ23	343	298,4	8xØ22,2	14	390	195	160	646	84	166	234	—
250	19	250	350	12xØ23	406	361,9	12xØ25,4	16	450	225	190	696	84	166	284	142
300	34	300	400	12xØ23	483	431,8	12xØ25,4	21	540	270	225	804	80	185	360	180
350	58	350	460	16xØ23	530	476,2	12xØ28,6	26	660	330	270	874	80	190	420	210

Type AL	O*	U	V	X**	Y	Z	AA	BB	CC	DD	EE	FF	GG	ZZ
150	100	3xM6	4xM10	1/4" (Ø10)	40	UNEF 1 1/8"	37,1	37,1	52,5	8	30	33	35	532
175	100	3xM6	4xM10	1/4" (Ø10)	53	UNEF 1 1/8"	37,1	37,1	52,5	8	30	33	35	592
200	125	3xM8	4xM12	1/4" (Ø10)	65	UNEF 1 1/8"	55,4	32	64	10	32	35	43	692
250	125	3xM8	6xM12	1/4" (Ø10)	75	UNEF 1 1/8"	55,4	32	64	10	32	35	43	767
300	125	3xM10	6xM12	1/4" (Ø10)	95	UNEF 1 1/8"	73,6	85	42,5	10	38	41	44	915
350	125	3xM10	6xM12	1/4" (Ø10)	112	UNEF 1 1/8"	73,6	85	42,5	10	38	41	44	1000



BL DAIRY

Versions of the BL type are also available with enlarged inlet: 175/200, 200/250, 250/300 and 300/350. Sizes of height and diameter of inlet are different. The second number indicates the size of the inlet flange.

Technical modifications are possible, dimensions in mm

BL.M.04.00.E

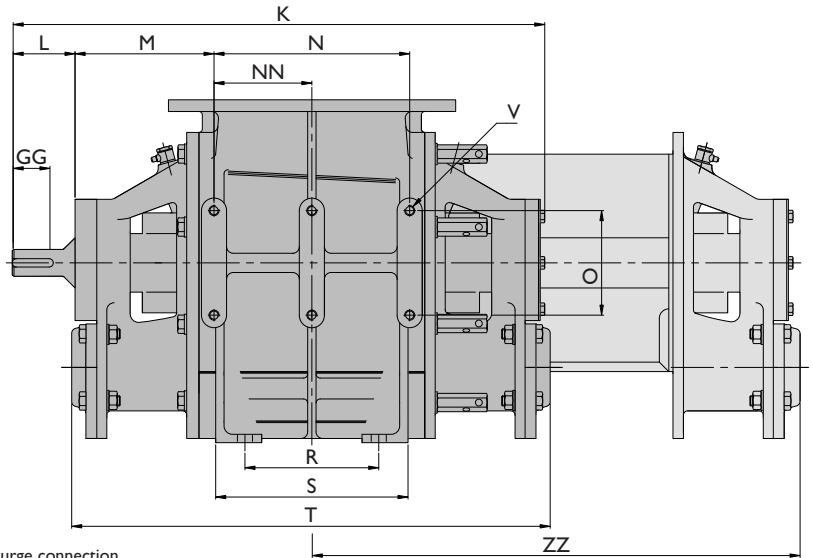
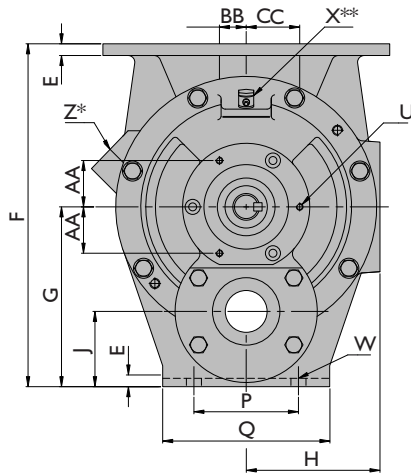
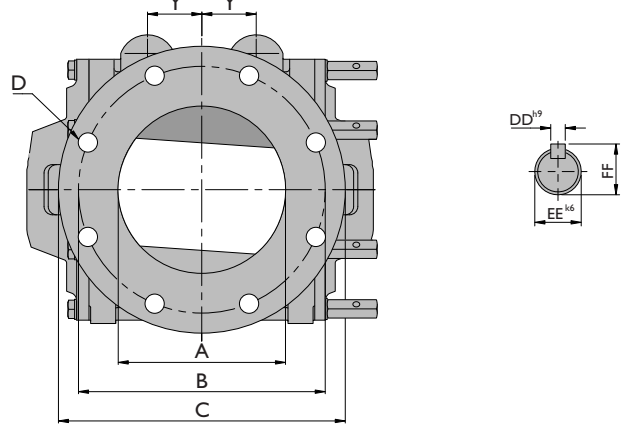
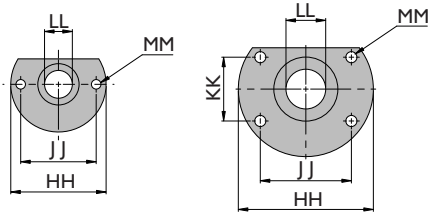

* Standard not pre-drilled
 Standaard niet voorgeboord
 Standard nicht gebohrt
 Standard pas percé
 Standard no taladrado
 Standard non preforato

** Air purge connection
 Aansluiting luchtfafdeling
 Luftspülanschluss
 Connexion insufflation d'air
 Entrada aire fluidificación
 Ingresso aria di flussaggio

<--DISASSEMBLY DIMENSION-->
 <--DEMONTAGEMAAAT-->
 <--DEMONTIERMASSE-->
 <--DIMENSION DE DÉMONTAGE-->
 <--DIMENSIONES DE DESMONTAJE-->
 <--DIMENSIONI INGOMBRO SMONTAGGIO-->

Type BL	Ltr/rev	DIN			ANSI			E	F	G	H	J	K	L	M	N	NN	O	P	Q	R	S
		ØA	ØB	D	ØC	ØB	D															
150	2,5	150	240	8xØ23	285	241,3	8xØ22,2	12	295	155	110	65	521	72	151	146	—	100	110	140	100	154
175	5,5	175	270	8xØ23	315	—	—	14	340	175	130	75	561	72	149	190	—	100	130	160	130	190
200	10,5	200	295	8xØ23	343	298,4	8xØ22,2	14	410	215	160	90	646	84	166	234	—	125	160	200	160	230
250	19	250	350	12xØ23	406	361,9	12xØ25,4	16	470	245	190	100	696	84	166	284	142	125	170	210	200	274
300	34	300	400	12xØ23	483	431,8	12xØ25,4	21	565	295	225	120	804	80	185	360	180	125	190	240	260	350
350	58	350	460	16xØ23	530	476,2	12xØ28,6	26	665	335	270	132	874	80	190	420	210	125	220	270	310	410

Type BL	T	U	V	W	X	Y	Z	AA	BB	CC	DD	EE	FF	GG	HH	JJ	KK	LL	LL max.	MM	ZZ
150	462	3xM6	4xM10	4xØ12	1/8"(Ø10)	40	UNEF 1 1/8"	37,1	37,1	52,5	8	30	33	35	120	95	—	35	50	2x12	540
175	502	3xM6	4xM10	4xØ14	1/8"(Ø10)	53	UNEF 1 1/8"	37,1	37,1	52,5	8	30	33	35	140	103,9	60,4	50	65	4x12	600
200	572	3xM8	4xM12	4xØ18	1/8"(Ø10)	65	UNEF 1 1/8"	55,4	32	64	10	32	35	43	170	114,7	80,3	50	80	4x14	700
250	622	3xM8	6xM12	4xØ18	1/8"(Ø10)	75	UNEF 1 1/8"	55,4	32	64	10	32	35	43	190	125	100	70	100	4x14	775
300	724	3xM10	6xM12	4xØ23	1/8"(Ø10)	95	UNEF 1 1/8"	73,6	85	42,5	10	38	41	44	230	163,8	114,7	100	125	4x14	915
350	794	3xM10	6xM12	4xØ23	1/8"(Ø10)	112	UNEF 1 1/8"	73,6	85	42,5	10	38	41	44	244	152	152	125	150	4x14	1000

Technische wijzigingen voorbehouden, maten in mm.

AL-BL DAIRY

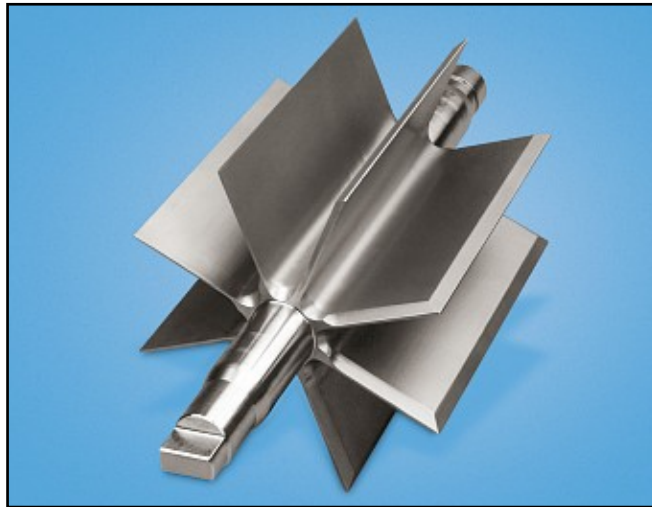

With the standard Daibi rotor the friction between end cover and rotor is minimal.

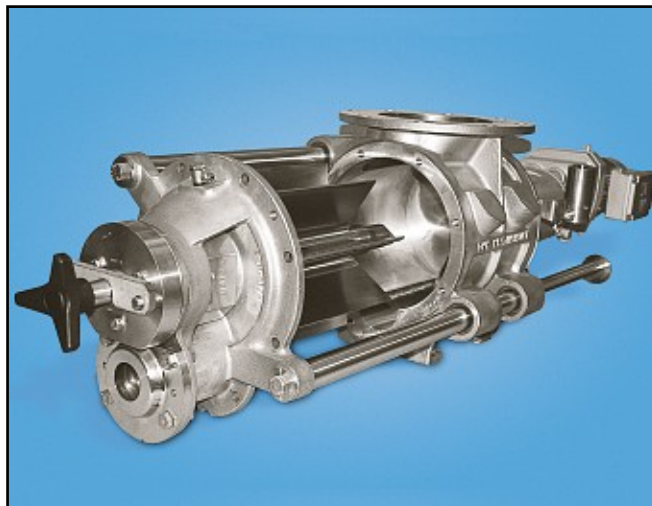

The AL and the BL Dairy valves are also available in the MZC-version with centrally placed supporting bars for easy removal of end cover and rotor. (see special product leaflet)

DMN-WESTINGHOUSE have been designing and manufacturing rotary valves, diverter valves and other related components for the bulk solids handling industry for more than 30 years. Offering tailor made solutions for chemical, food, plastics and pharmaceutical industries, DMN-WESTINGHOUSE products are distributed worldwide.

Besides an extensive range of standard components, we supply USDA accredited sanitary versions and ATEX approved explosion-proof models.

An extensive network of subsidiaries, distributors and representatives ensures a high level of service and support all over the world.

© DMN - HOLLAND - 04/05



Head Office:
DMN Machinefabriek
Noordwykerhout BV
P.O. Box 6, NL - 2210 AA
Noordwykerhout, Holland
Tel. +31 252 361 800
Fax +31 252 375 972/934
dmn@dmn-nwh.nl

DMN Incorporated
3895 South Perkins Road, Suite 8
Memphis, TN 38118, USA
Tel. +1 901 360 1537
Fax +1 901 360 0348
dmnfo@dmn-inc.com

DMN UK Ltd
Unit 1&2, Harris Road,
Porte Marsh Industrial Estate
Calne, Wiltshire, SN 11 9PT, UK
Tel. +44 1249 818 400
Fax +44 1249 818 410
dmn@dmnuk.com

DMN Schüttguttechnik GmbH
Rütgersstrasse 8
D-21244 Buchholz i.d. Ndh, Germany
Tel. +49 4181 931 40
Fax +49 4181 931 490
dmn@dmn-schuettguttechnik.de

DMN France SAS
65, rue Charles de Gaulle
91330 Yerres, France
Tel: +33 1 69 49 85 70
Fax: +33 1 69 49 85 79
dmnfrance@wanadoo.fr

www.dmn.info

DMN
WESTINGHOUSE